

Specification

CUSTOMER: 1119 : PART NO.: _____ : REF VA60B-120400 : _____	VDSON P/N: VA60B-120400 : DESCRIPTION: AC ADAPTER : DATE: 2008/7/31 REV.: 1.0 : _____
--	---

CUSTOMER APPROVAL SIGNATURE

Please return one copy after approved

WRITED BY	CHECK BY	APPROVED BY

CHECK LIST

- 1Cover /**
- 2Check list /**
- 3Recode of revision /**
- 4Electrical performance /**
- 5Engineering drawing**

RECORD OF REVISION

NO.	REASON	DESCRIPTION OF CHANGES	REMARKS	DATE

General

The specification defines the performance characteristics of a 48.0 Watt , +12.0V Output level switching power supply for _____ . The power supply has designed highly reliable and meet interaction safety and radiation requirements.

1. Input requirements

1.1 Input voltage range

Type	Input voltage range	
AC supply power	100Vac	240Vac
AC Operation range	90Vac	264Vac
Frequency	47-63Hz sine wave	47-63Hz sine wave

1.2 Input Current

1.5A	At AC input voltage 100v and DC output full load AC 100Vac DC
------	--

1.3 Input protection

2.0A Fuse	The power supply shall be protected from any abnormal condition
-----------	---

1.4 Input Inrush current

Less than 60A	The Initial input current, Ambient temperature 25
Without AC output	

1.5 Efficiency

Not Less Than 80%	Output with full loading at AC input 100Vac240Vac
-------------------	---

1.6 Power Saving

Not more than 0.5W	At AC 100Vac240Vac input and output min load.
--------------------	---

1.7. Power factor

Test condition			Design Requirement
AC input	DC output		
100Vac240Vac	+12.0V	4.0A	0.50

1 Output Requirements

1.7 Turn on delay

2000ms max	At AC 100Vac240Vac input and output full load
------------	---

* Test on delay is measured from 0 voltage output to the main output regulation.

1.8 DC Output Regulation

Voltage	Loading(A)			Tolerance Range	Adjustable voltage Range
	No Loading	Full loading	Peak Current	Total Regulation	
12.0V	0A	4.0A	4.0A	5%	11.4V12.6V

* Total regulation involved line regulation load regulation cross regulation --- etc.

* Line regulation is measured from 100Vac240Vac

* Load regulation is measured all output from min load to max load at 100Vac240Vac nominal AC input voltage.

1.9 .Output Combine Regulation & Ripple/Noise test

Test condition			Design Requirement	
AC input	DC output		Ripple/Noise	Regulation
100v240Vac	+12.0V	4.0A	200mVp~p	11.4V12.6V

Note 1: The ripple/noise voltage of the outputs shall be Measured at the pins of the mating output connect.

Note 2: A high frequency 0.1uf multi-layer(type X7R) and 47uf electrolytic(low ESR) Capacitor shall be used to terminate each output at the measurement point.

1.10 Led Indicator

LED Indicator Light	Status
Light	
No Light	

2 Protection

2.7 .Over Voltage Protection

The power supply should shutdown fro any cause of over voltage conditions before output exceeds its limits below.

Nominal Output Voltage (V)	Over Voltage (V)
+12.0	+18.0

The power supply is latched and power on reset is required.

3.1. Short circuit protection

Testcondition		Design Requirement
AC Input	DC Output	
100Vac240Vac	Short output Terminal of DC Plug +and -	Shutdown and Autorecovery

3.2. Over Current Protection

The power supply shall provide over current protection on output. Maximum current inception point o output shall be limited to the following values:

Output Voltage(V)	Over Current Protection(A)
+12.0V	6.5A +5%

The power supply will recover automatically after the overload is removed. Power on reset is not required.

3 Cooling method

Cooling method	
By ____ mm Fan Force Air Cooling	
By Nature Air	

5.Ground Leakage Current

The power supply ground leakage current shall be less than 500 uA (max) 240Vac Input and earth ground open.

6.HI-POT Test

Apply DC 3KV on primary to secondary for 60 sec. No components damage, No arting, No noise, and the cut off current shall below 5mA.

7. Insulation resistance

Apply DC 500V to primary-secondary and measured the resistance shall be large than 100M ohms.

8.Electro Magnetic Compatibility

Power supply for use with the host system will be tested to conform with the following emission standards.

8.1.EMI

8.1.1. CISPR Requirements CE

Power supply shall conform to the Class B" requirements of CISPR 22.

8.1.2. VCCI Requirements FCC

Power supply shall conform to the Class II requirements of VCCI.

8.2. EMS

The power supply shall meet below EMS requirement.

8.2.1. EN61000-4-2 ESD

Air Discharge $\pm 15\text{KV}$, Contact discharge $\pm 8\text{KV}$.

9. Safety Requirements

The power supply must comply with the following national standards:

IEC60950 (

IEC60065 (

IEC60335 ()

UL 1310 (

GB4943

GB8898

10. Environment

10.1 Temperature and Humidity

Operating Temperature	0°C ~ 40 °C
Storage Temperature	-10°C ~ 60 °C
Operating Humidity	20% ~ 90% RH.
Storage Humidity	8% ~ 95% RH.

11. M.T.B.F

Shall be 35000 power on hours on greater under 25 degrees C of ambient temperature MTBF under evaluated under.

12. Mechanical

12.1 Dimension unit :(mm)

L($\pm 0.5\text{mm}$)	W($\pm 0.5\text{mm}$)	H ($\pm 0.5\text{mm}$)
116.0	60.0	34.0

12.2 Weight (g)

300.0g

工程开模图

样品需求图

正式发行图

2008/07/31

Date

A

B

C

D

E

A

B

C

D

E

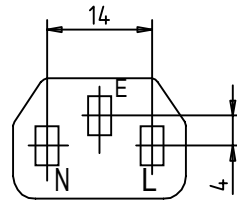
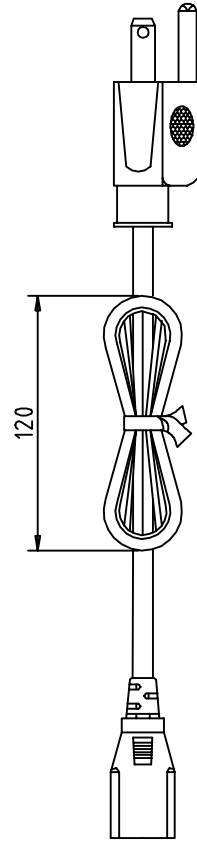
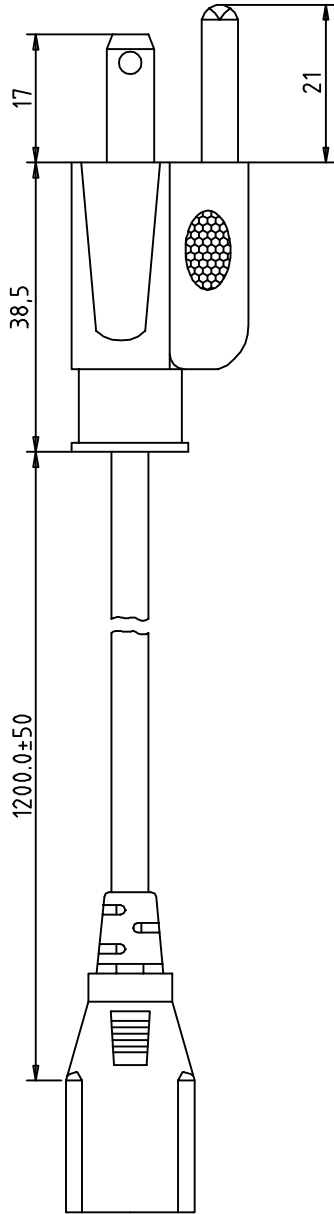
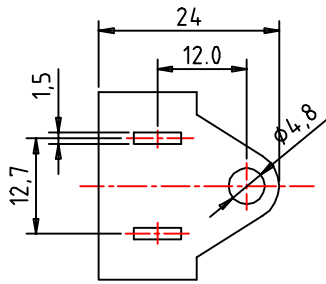

TOLERANCE			
CLASS	A	B	C
0-5	±0.10	±0.15	±0.20
5-20	±0.15	±0.20	±0.30
20-50	±0.20	±0.30	±0.40
50-100	±0.30	±0.40	±0.60
100-UP	±0.50	±0.60	±1.00
ANGLE	±40'	±90'	±180'

Tolerance: C

Material:

Unit: mm

Project: 

Designed by
Qiu WeiQiang

Checked by

Approved by - date

File name

Model
VAxxA

Scale
1:1

Title
A

Part no.

Edition
1.0

Sheet
1/1

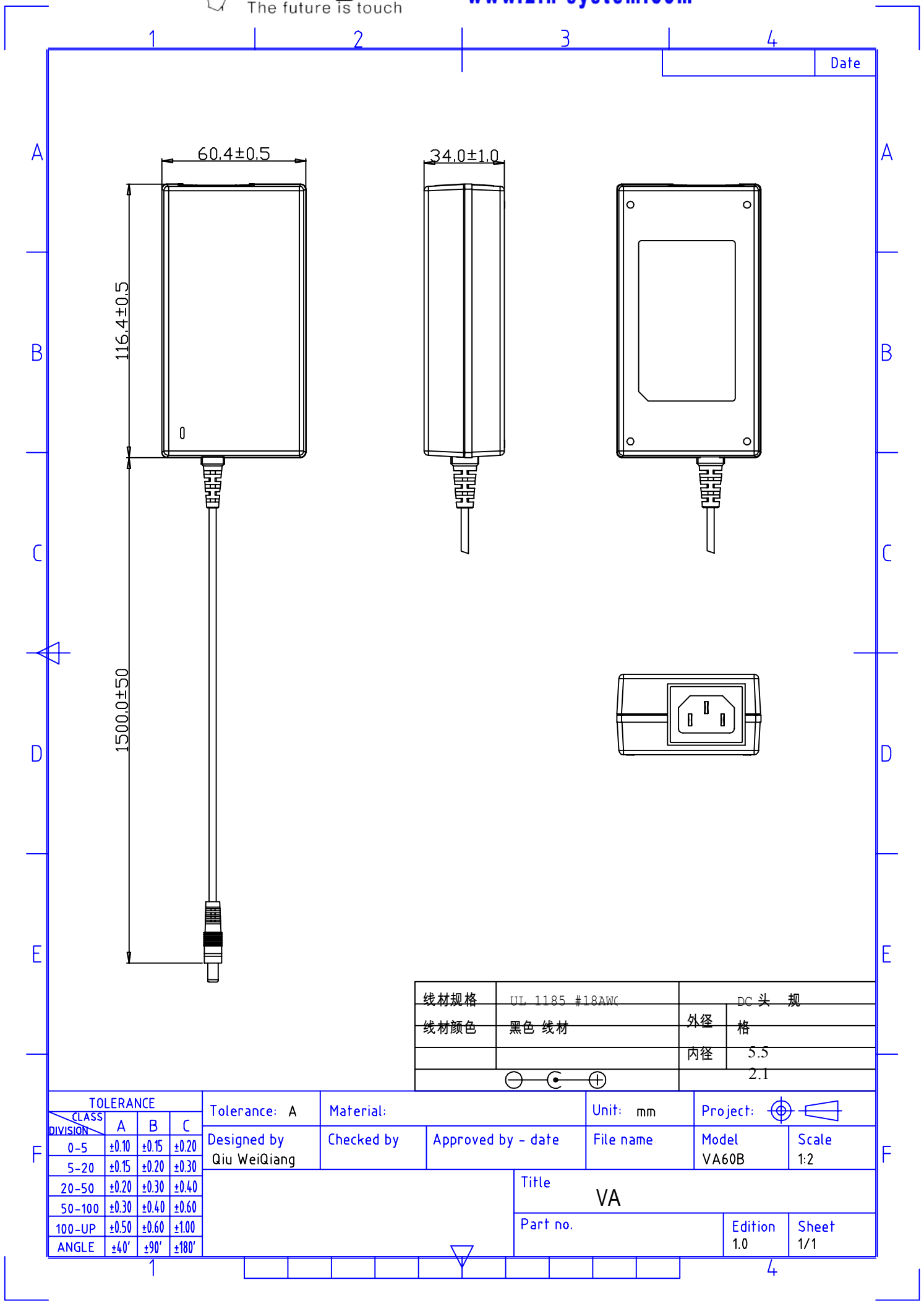

Date

线材规格	UL 1185 #18AWG	DC头 规	
线材颜色	黑色 线材	外径	格
		内径	5.5
			2.1

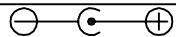

TOLERANCE			
CLASS	A	B	C
0-5	± 0.10	± 0.15	± 0.20
5-20	± 0.15	± 0.20	± 0.30
20-50	± 0.20	± 0.30	± 0.40
50-100	± 0.30	± 0.40	± 0.60
100-UP	± 0.50	± 0.60	± 1.00
ANGLE	$\pm 40'$	$\pm 90'$	$\pm 180'$

Tolerance: A		Material:		Unit: mm	Project:	
Designed by	Checked by	Approved by - date		File name	Model	Scale
Qiu WeiQiang					VA60B	1:2
				Title		
				VA		
				Part no.	Edition	Sheet
					1.0	1/1

1	2	3	4
RevNo	Revsien note	Date	Signature Checked

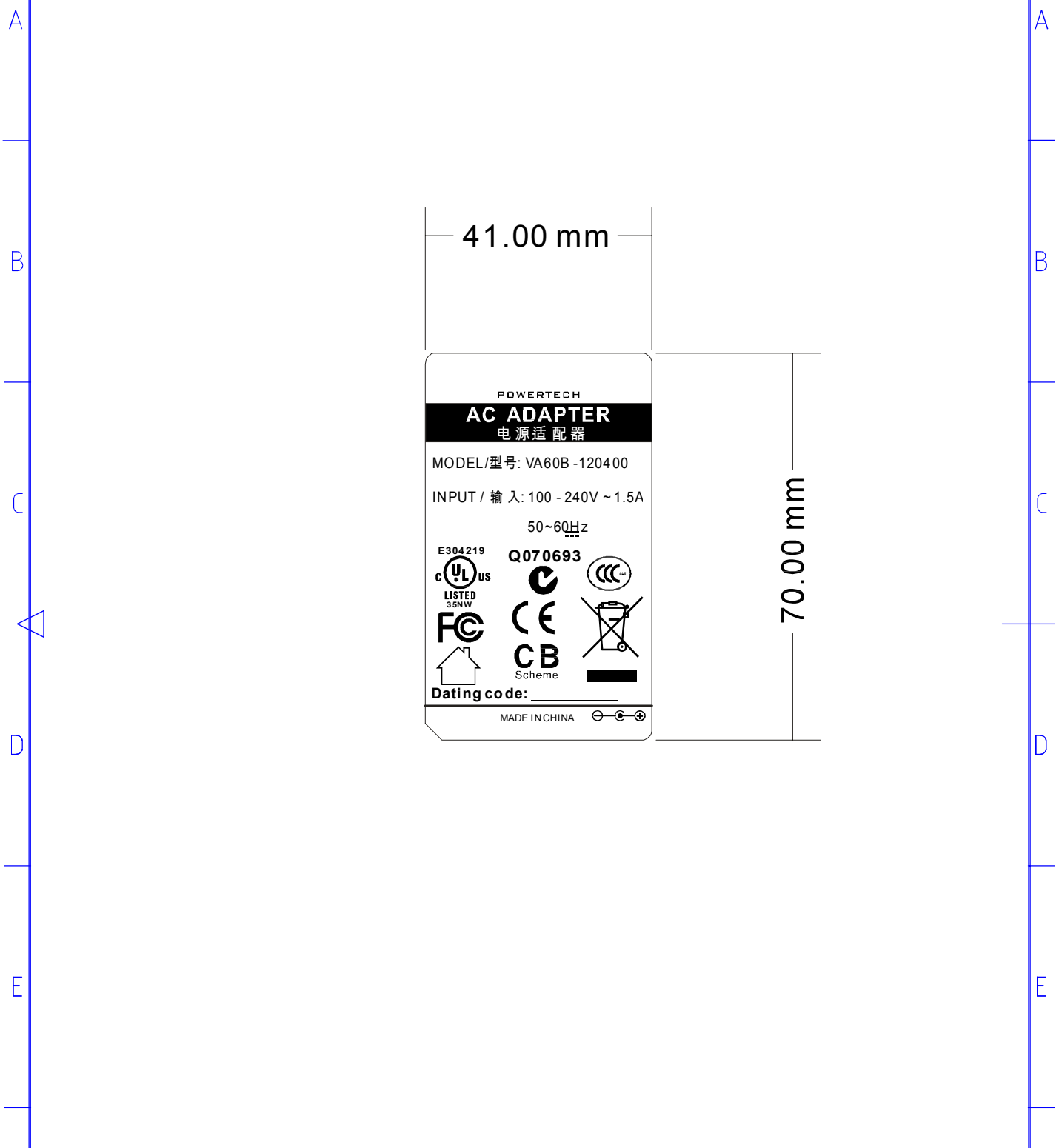

TOLERANCE				Tolerance: A	Material:	Unit: mm	Project:	
CLASS DIVISION	A	B	C	Designed by	Checked by	Approved by - date	File name	
0-5	±0.10	±0.15	±0.20				Model V A60B	
5-20	±0.15	±0.20	±0.30				Scale 1:1	
20-50	±0.20	±0.30	±0.40	Title VA60B Series Model La				
50-100	±0.30	±0.40	±0.60					
100-IP	±0.50	±0.60	±1.00	Part no. bel		Edition	Sheet	
ANGLE	±0°	±90°	±100°					1 / 1